

RoHS Compliant

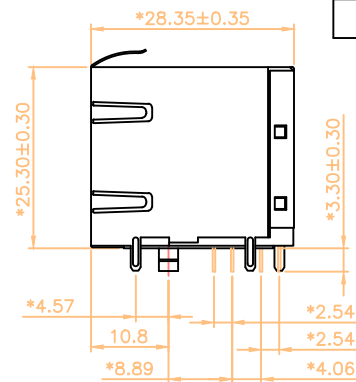
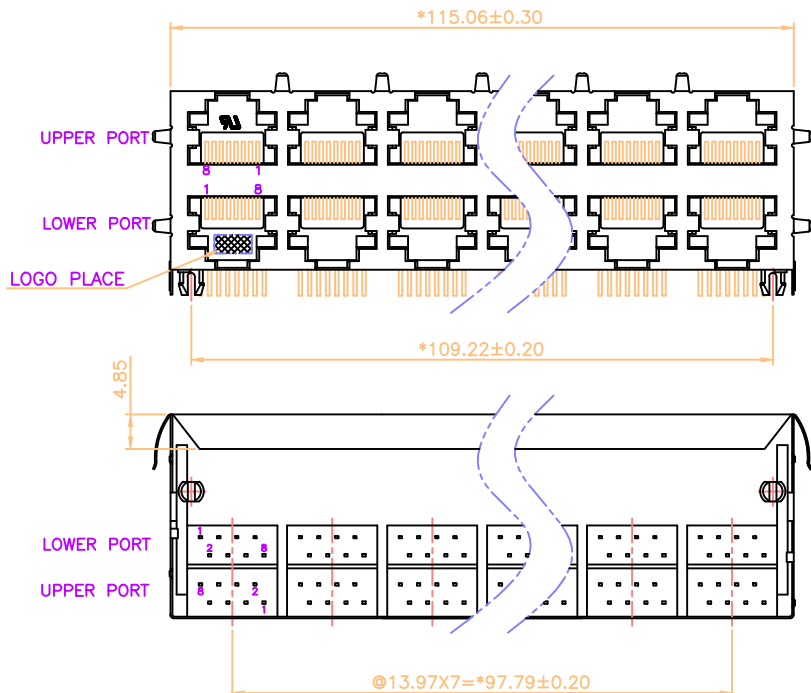

NOTES:

ELECTRICAL:

1. VOLTAGE RATING : 125 VAC RMS.
2. CURRENT RATING : 1.5 AMP.
3. CONTACT RESISTANCE : 60 MILLIOHMS MAX.
4. INSULATION RESISTANCE: 1000 MEGOHMS MIN @ 500 VDC.
5. DIELECTRIC STRENGTH : 1000 VDC RMS 60Hz, 1MIN.

MECHANICAL:

1. HOUSING MATERIAL : PBT UL94V-0./COLOR:BLACK.
2. INSERT MATERIAL : PBT UL94V-0./COLOR:BLACK.
3. SHIELD MATERIAL : BRASS.
4. CONTACT MATERIAL : PHOSPHOR BRONZE t=0.35mm.
5. PLATING : GOLD PLATING OVER NICKEL.
6. OPERATING LIFE : 750 CYCLES MIN.
7. PCB RETENTION PRE-SOLDER : 1 LB MIN.
8. PCB RETENTION POST-SOLDER: 10 LBS MIN.

ENVIRONMENTAL:

1. STORAGE : -40°C TO +85°C.
2. OPERATION: -40°C TO +85°C.
3. WAVE SOLDERING TEMPERATURE: 230°C~240°C(3~5 SECONDS).
4. RoHS COMPLIANT.

MATES WITH MODULAR PLUG CONFORMING TO
FCC PART 68, SUBPART F.
CUL FILE NO.E345295
PART NUMBER: ZW2988-9BXXSHX

02-W/O LOGO
1-3u" 2-6u" 3-15u"
4-30u" 5-50u" F-GOLD FLASH

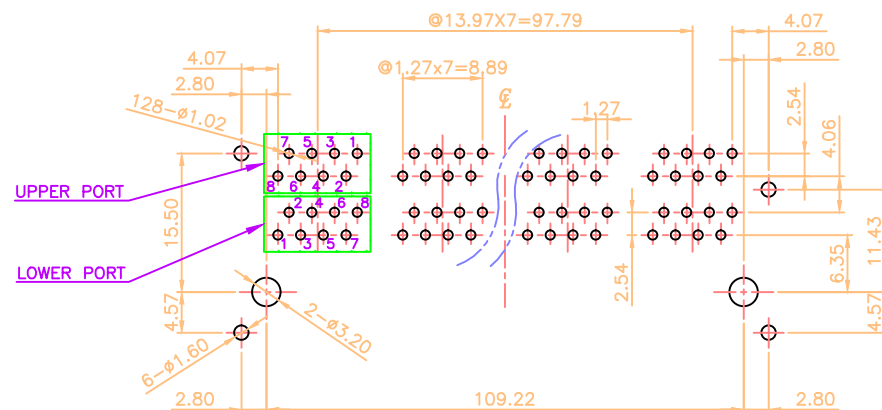

PC Board Layout Component Side View
PC Board Thickness=1.6mm
Tolerance±0.05

Inspection Item	DIMENSION IN mm [Inch]		ZSNOW ELECTRONIC CO., LTD	
	TOLERANCE UNLESS OTHERWISE SPECIFIED			
	.X± 0.30	X.*± 2.0"	SEE NOTE	ZW2988-9BXXSHX-1
	.XX± 0.20	.X.*± 1.0"	TITLE	
.XXX± 0.10		RJ45 STACKED GANGED JACK, 2X8		
APPROVE	CHECK	DRAW	PROJ.	SHEET 1 OF 1
TIM	ZERO	HAPPY		REV P1
05/20/16'	05/20/16'	05/20/16'	SCALE 3:2	SIZE A3

THIS INFORMATION IS CONFIDENTIAL AND IS DISCLOSED TO YOU ON CONDITION THAT NO FURTHER DISCLOSURE IS MADE BY YOU TO OTHER THAN ZSNOW ELECTRONICS PERSONNEL WITHOUT WRITTEN AUTHORIZATION FROM ZSNOW ELECTRONICS CO., LTD.